

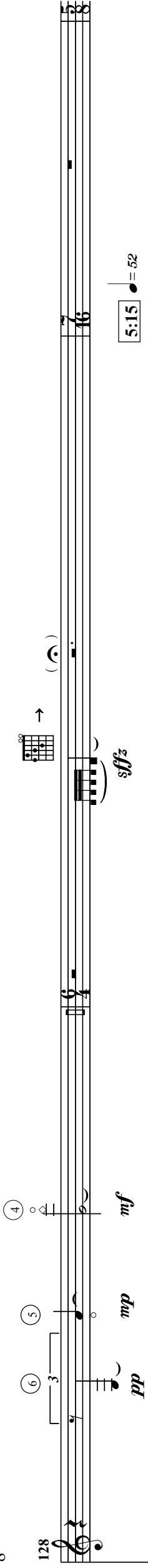

128  *pp* *mp* *mf* *sffz*



5:15  = 52

Hammer-on (bring out bi-tones where possible)

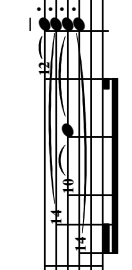
131  *f*

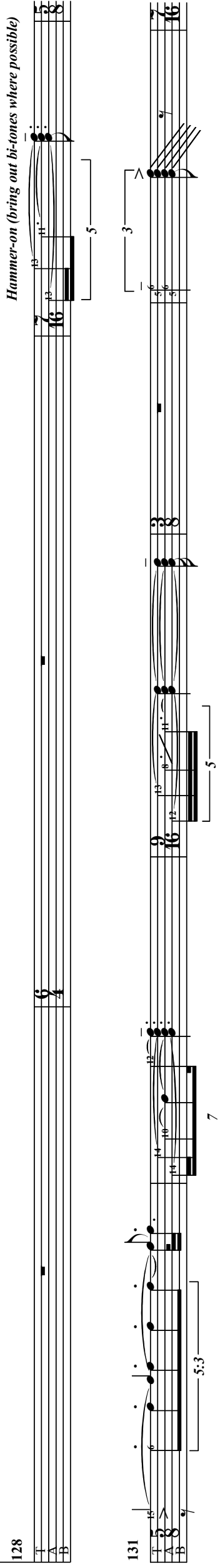

5:3 *p* *mf* *f* *7:5* *f*

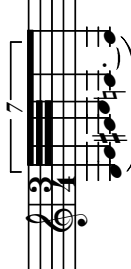
136  *f*

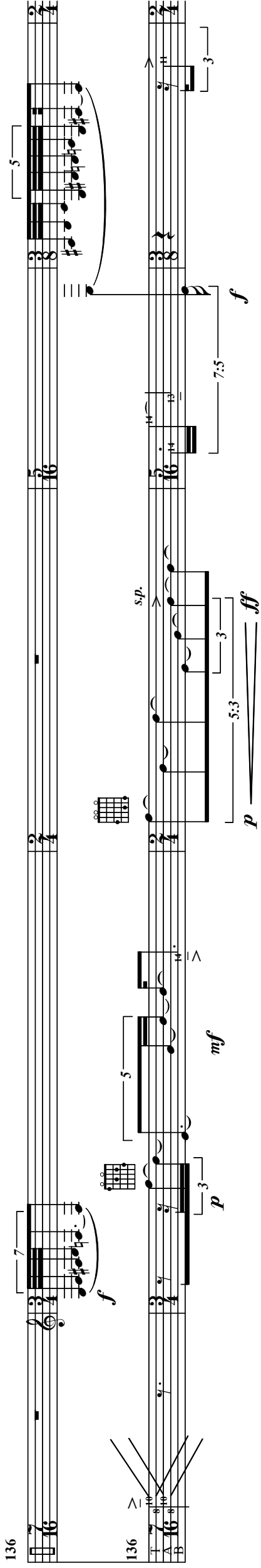

5:3 *p* *mf* *f* *5:3* *ff* *7:5* *f*

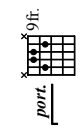
141  *p* *f*

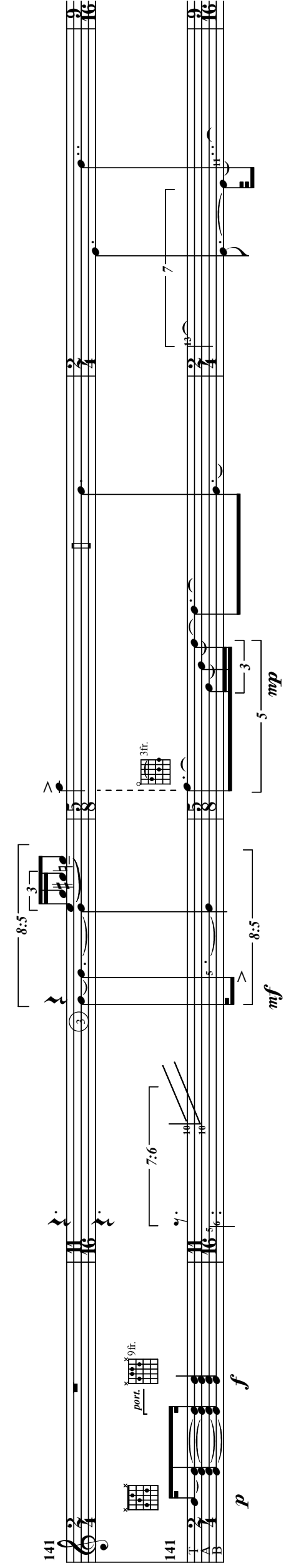

8:5 *mf* *8:5* *mf* *7:6* *p* *mp* *5* *mp*

145 $9/16$ $7/16$ $3 \frac{1}{2}$ 6 $1 \frac{1}{2}$
pp *7* *pp* *mute strings* *ff*
mf *f* *10:7* *3* *10*
mf *7* *6* *7* *6*
7:6 *7* *5:3* *5*
 $7/16$ $7/16$ $7/16$ $7/16$
mf *7* *6* *7* *6*
mf *7* *6* *7* *6*

149 $2/4$ $2/4$ $2/4$ $2/4$
mf *sfz* *m.s.p.* *mf*
mf *mf* *mf* *mf*
 $5:3$ 3 $5:3$ $5:3$
s.p. *w/nails* *6ft.* *ord.* *w/fingers* $5:3$ $5:3$
 3 3 3 3 3 3
3ft. *7* *5* *7* *3* *7*
 $7/16$ $7/16$ $7/16$ $7/16$ $7/16$ $7/16$ $7/16$ $7/16$

154 $9/16$ $7/16$ $3 \frac{1}{2}$ 6 $1 \frac{1}{2}$
mf *mf* *mf* *mf* *mf* *mf* *mf* *mf* *p* *p* *mp* *mp*
7 *7* *7* *7* *7* *7* *7* *7* *7* *7* *7* *7*
7:6 *7* *5:3* *5*
 $7/16$ $7/16$ $7/16$ $7/16$ $7/16$ $7/16$ $7/16$ $7/16$ $7/16$ $7/16$ $7/16$ $7/16$

157 $2/4$ $2/4$ $2/4$ $2/4$
mf *mf* *mf* *mf* *mf* *mf* *mf* *mf* *mf* *mf* *mf* *mf* *mf* *mf* *mp* *pp* *mp*
 $6:45$ 5 3 $7:5$ 3 7
 $7/16$ $7/16$ $7/16$ $7/16$ $7/16$ $7/16$ $7/16$ $7/16$ $7/16$ $7/16$ $7/16$ $7/16$ $7/16$ $7/16$ $7/16$ $7/16$ $7/16$

162

mf

sffz

5

7

3

5:3

5

167

take stick

5

5

3

5

3

7:15

● = 48

mute str.

171

detune 1-string 3/4 step up

mute strings

detune 2-string 1/4 step up

8:5

3

3

3

5:3

175 *mute str.*

175 *across strings*

7:5 5:3 3

180 **7:45**

180 *w/nails* *s.p.*

pp *mf* 7 3

180 *w/fingers* *6ft.*

f *across strings* 5 3

184 *mute str.*

184 *7ft.*

fff *ff* 5 3 7:6 5:3

8 1/2